

TANA SHARK & HAMMERHEAD

MOBILE WASTE SHREDDERS

TRACKS | SEMI-TRAILER | STATIONARY



TANA SHREDDERS – For increased profits

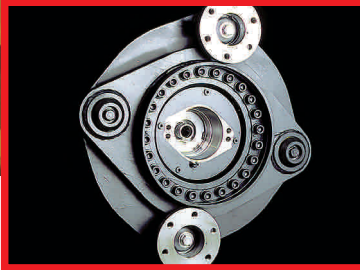

Rotor carrier assembly, swing frame (US pat.) protecting the gears.

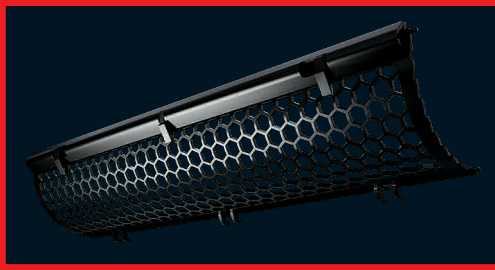

Screens with a variety of mesh sizes to adjust particle size.



Hard weld surfacing to prolong the life span of the rotor tube.



Bolt-on, reversible rotor knives.

Getting the most out of your investment

TANA shredders have been engineered to provide maximum uptime. Their robust design, proven materials, excellent serviceability, and ease of operation are features that keep them reliable delivering the performance and profit you are looking for.

The TANA Control System (TCS) together with TanaConnect® allows you to tune your process and to use TANA shredders to the max. It tracks process information in real time, whether it is fuel consumption, fault codes, uptime information, or capacity. The scaling system weighs the shredded materials throughout the process. This information is transferred automatically to TanaConnect® which provides you with reports by waste fractions (option).

TANA Shredders in general

The TANA waste shredders are hydraulically driven, electric or diesel engine powered, single shaft, low-speed mobile shredders. Operation and hydrostatic transmission

are controlled by TANA Control System (TCS). The TANA TCS protects the machine from overloading, overheating, and possible damage caused by non-crushable material.

Unique versatility

TANA shredders are suitable for the shredding of most reusable, recyclable, and recoverable materials. The purpose may be volume reduction, refuse derived fuel production, or recyclable material production.

The key to productivity are the machine's versatility. They are able to handle materials from MSW to waste wood, from plastics to tires, and they can be used either as a pre-shredder or to produce the required particle size in one phase.

Flexible operations

By adjusting the amount of counter knives, the end product size can be regulated, and with an adequate rotor screen, it can be fine-tuned and the optimal end product size-capacity ratio achieved. Both the rotor

knives and the counter knives have two wearing surfaces that prolong their service life. Rotors and counter knives are available with different coatings as an option.

Homogeneous particle size

The rotor to screen clearance has a major impact on the overall productivity of the shredder and uniform quality of the output. In TANA shredders, this clearance can be finetuned for maximum performance.

Screens are available in different mesh shapes and sizes which the operator can choose from according to the requirements he has for the end product size.

The simple and robust counter knife design adds to the versatility. The amount of the counter knives can be adjusted and they have two wearing surfaces.

TANA shredders have a variety of options to choose from:

- Electric fuel refill pump
- Engine air-intake pre-cleaner
- Extension to conveyor
- TanaConnect® reports

Maximum operational versatility



TCS with 16 pre-programmed operations, connected with TanaConnect®.



Swing out doors allow easy access to the power pack.



TanaConnect® is an integrated information management system that collects real-time and detailed data about the shredding process.

Service and support

TanaConnect®

Through TanaConnect® the operation can be followed in real time. Critical alarm notifications help to prevent potential problems, and if something happens, troubleshooting and diagnostics are faster and more accurate, minimizing downtime. As a machine owner you will have control of the machine anywhere and anytime.

Maximum uptime

- Remote access for quicker and more accurate trouble shooting by the distributor and TANA technical support
- Critical alarm notifications to several receivers by e-mail
- Reminders for scheduled maintenance to several receivers by e-mail

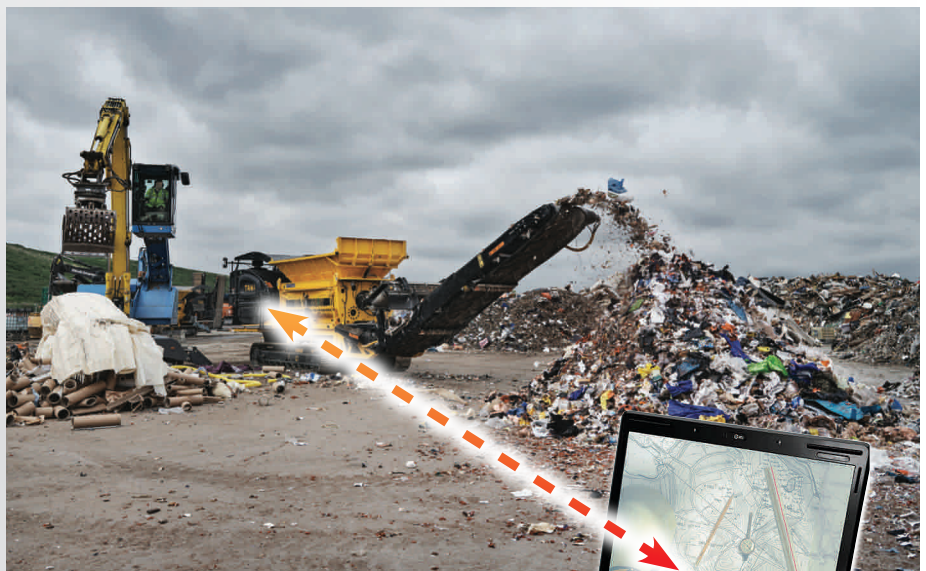

TANA SHREDDERS – Versatile

Unique features of TANA Shredders

TANA Powerpack

Side-opening engine covers give easy access to service points that are designed to be user-friendly. Service platforms around the machine make daily maintenance more comfortable, efficient and safe.

TANA Control System (TCS)

TANA TCS has been updated with a new touchscreen display module. Choose one of the 16 preset shredding programs to ensure an optimized process.

Innovative swing frame

The patented swing frame system protects the gearbox and prevents breakdowns.



TanaConnect®

TanaConnect® provides online access to your machine wherever you are. For maximizing machine uptime and optimizing your operations.

TANA

NORTH AMERICA

Overband magnet

Separating ferrous metals from the shredded material results in a cleaner end product. The height and direction can be controlled easily through TCS.

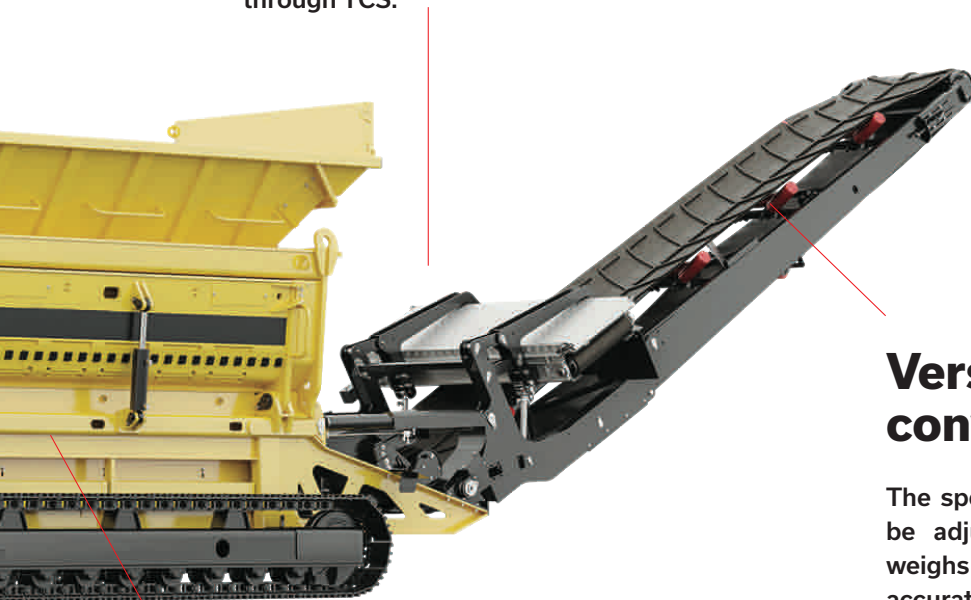

Versatile 2-part conveyor with scale

The speed and direction of each conveyor can be adjusted separately. The conveyor scale weighs the shredded material so you can accurately monitor your process. The usability of the magnet is state of the art – the height of the magnet can be adjusted and it can be turned off and back on again during operation. The direction of the magnet to the left or right can be chosen, which improves flexibility.

Torque and robustness

The highest torque on the market and robust structure ensure its capability to shred the toughest materials, like big tires and ragger wire.

Folding hopper side wall



Bolted cleaning combs

CUSTOMER BENEFITS

Less Investment

One machine vs. multiple machines

Increased Flexibility

Change screens in less than 1 hour

Optimized End Product Size and Capacity

Purpose-built rotor, counter-knife sidewall design, and rotor screen sizing options

High Level of Uptime

Quick change of rotors, knives, and counter-knives. Easily remove obstructions with sidewall opening capability

Hydraulic Door for Easy Rotor Access

Quick access to maintain hopper and counter knives to increase productivity

Built for the Landfill Life™

Tough, versatile shredders that last

Unique versatility

Investing in a TANA shredder opens multiple opportunities. The TANA Shark & Hammerhead are able to produce a homogenous particle size and have the capability to process the widest range of materials - even the toughest ones. Our shredders offer even more flexibility than before thanks to a wider variety of rotors, screen sizes, and platforms. All our shredders are electric or diesel powered.

Ease of use

TANA shredders are extremely easy to adjust. Integrated screens are used to adjust the end product size and can be changed in just ten minutes. Non-crushables can be removed through the opening side wall. The TANA Control System (TCS) offers 16 preset operating programs for different types of waste. The touchscreen is state of the art, and software updates can be done remotely.

Ease of maintenance

Easy access to all service and maintenance points is one of the most appreciated features of TANA products. Optimal ergonomics maximize uptime. The opening side wall provides access to the rotor and the counter knives making rotor maintenance smooth and easy compared to other players on the market. Easy access to service points makes daily routines more efficient, rain or shine.



TANA SHREDDERS – Robust and reliable

General Information	D	DT	ET	EM	E
Operating Weights	64,250 lbs - 72,750 lbs (29,152 kg - 33,008 kg)	69,750 lbs - 78,250 lbs (31,647 kg - 35,504 kg)	70,000 lbs - 78,500 lbs (31,760 kg - 35,617 kg)	66,500 lbs - 75,000 lbs (30,172 kg - 34,029 kg)	49,250 lbs - 66,000 lbs (22,346 kg - 29,946 kg)
Total length in transportation	33 ft 8 in (10,270 mm)	33 ft 8 in (10,260 mm)	33 ft 8 in (10,260 mm)	33 ft (10,060 mm)	18 ft 11 in (5,770 mm)
Length in operation	51 ft 5 in (15,680 mm)	51 ft 8 in (15,750 mm)	51 ft 8 in (15,750 mm)	50 ft 9 in (15,480 mm)	18 ft 11 in (5,770 mm)
Total width	8 ft 4 in (2,530 mm)	8 ft 4 in (2,550 mm)	8 ft 4 in (2,550 mm)	8 ft 4 in (2,530 mm)	8 ft 3 in (2,510 mm)
Total height in transportation	13 ft (3,970 mm)	11 ft 10 in (3,600 mm)	11 ft 10 in (3,600 mm)	13 ft (3,970 mm)	9 ft 9 in (2,970 mm)
Engine	Cummins X15 Fulfills Tier 4 Final, EU Stage V		VEM, IE4	VEM, IE4	VEM, IE4
Rotor drive gears and rotor drive torque: Shark	2 x 162,260 ft-lbs, total 324,530 ft-lbs (440 kNm)		2 x 162,260 ft-lbs, total 324,530 ft-lbs		
Rotor drive gears and rotor drive torque: Hammerhead	2 x 114,350 ft-lbs, total 228,700 ft-lbs (310 kNm)		2 x 114,350 ft-lbs, total 228,700 ft-lbs		
Minimum supply fuse size			630A	630A	630A
Supply Voltage			480 V / 60 Hz	480 V / 60 Hz	480 V / 60 Hz
Shredding Tools	D	DT	ET	EM	E
Rotor shredding length	9 ft 10 in (3,000 mm)	9 ft 10 in (3,000 mm)	9 ft 10 in (3,000 mm)	9 ft 10 in (3,000 mm)	9 ft 10 in (3,000 mm)
Rotor speed max, rpm: Shark	28	28	28	28	28
Rotor speed max, rpm: Hammerhead	40	40	40	40	40
Rotor Diameter	3 ft (920 mm)	3 ft (920 mm)	3 ft (920 mm)	3 ft (920 mm)	3 ft (920 mm)
Rotor knives, pcs	33 / 44 (option)	33 / 44 (option)	33 / 44 (option)	33 / 44 (option)	33 / 44 (option)
Counter knives, pcs	23	23	23	23	23

Operating weight includes the basic machine (fuel tank full), overband magnet, screen support bars, and one screen.

Weights and measurements are given within normal tolerances. Manufacturer reserves the right to alter the above as necessary.

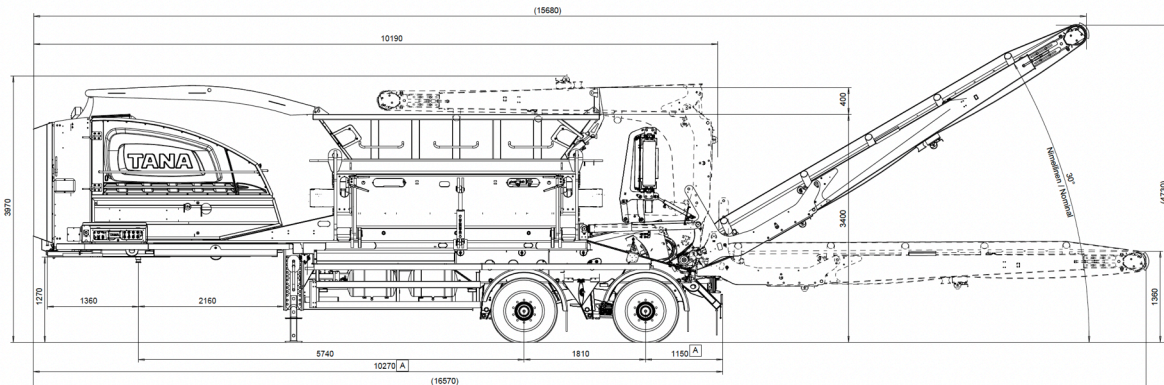

Shark & Hammerhead Shredder On Semi-trailer

- Bolt-on cleaning combs for easier maintenance
- Magnet conveyor improvements: discharge side selected from TCS + hydraulic magnet adjustment during operation

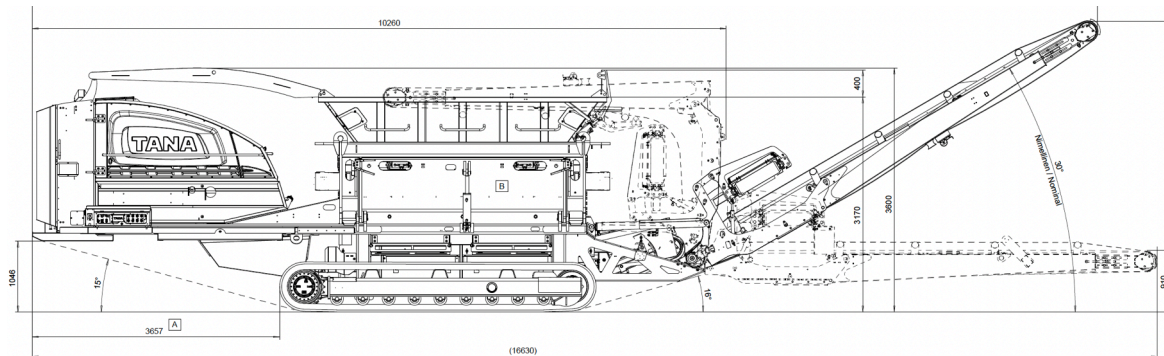

Shark & Hammerhead Shredder On Tracks

- Raised frame - more space to guarantee better material flow underneath the rotor
- Bolt-on cleaning combs for easier maintenance
- Magnet conveyor improvements: discharge side selected from TCS + hydraulic magnet adjustment during operation

Largest variety of toughest materials

- Tires
- Commercial & industrial waste (C&I)
- Construction and demolition waste (C&D)
- Municipal solid waste (MSW)
- Other types of special waste & side streams: ragger wire, plastics, pallets and waste wood, household waste, mattresses and furniture, paper, barbed wire, shingles



Tires



Plastics



C&I



C&D



Ragger wire



Wood waste

Service and parts

- Tana North America assigns each shredder to a service manager who monitors the machine daily.
- Our service team has a daily meeting to assure each issue is being addressed.
- 24/7 technical support number (844) 365-5394



Options

- Optional equipment helps you to make the most out of your TANA mobile shredder.
- Contact your sales representative and learn more about the available options.
- Choose the best screens, door, magnet, rotor design, and counter combs for your application.



Subscribe to our newsletter



DESIGNED TO IMPROVE YOUR BOTTOM LINE



Tana North America
3202 Clovis Road
Lubbock, Texas 79415

Tel. 806-771-9944
e-mail: sales@humdingerequipment.com
www.humdingerquipment.com | www.tananorthamerica.com

TANA
NORTH AMERICA